

Device	Specification
Flocculation Tank	Primary Reaction Tank Approx. Capacity 200L
	3φ 200V 0.4kW (50Hz/60Hz), Reduction Gear Ratio 1/30
	Rated Current Value 2.2A(50Hz), 2.0A(60Hz)
Raw Water Pump	Secondary Reaction Tank Approx. Capacity 200L
	3φ 200V 0.4kW (50Hz/60Hz), Reduction Gear Ratio 1/30
	Rated Current Value 2.2A(50Hz), 2.0A(60Hz)
Raw Water Pump	FG50-S7RC 3φ 200V 1.5kW Reduction Gear Ratio 1/3
	Rated Current Value 6.7A(50Hz), 6.1A(60Hz)
	Pump Performance Total Head 2m 90L/min (normal temperature, clear water)

Device	Specification
KDS Separator	Model SS-411D
	Casing Material: SUS 304 Thickness: 4.0mm
	Rotating Shaft Material: SUS 304
Screen	Flow Passage Width 380mm
	Rotating Oval Plates 11 rows (Material: SUS301-CSP 10.5)
	Gap 1.0mm
Drive Unit	Gear Motor 3φ 200V 0.4kw
	Reduction Gear Ratio 1/240
	Revolution Speed 6.04r/min(50Hz), 7.29r/min(60Hz)
Squeeze Method	Rated Current Value 2.35A(50Hz), 2.05A(60Hz)
	Class E Insulation, TEFC Outdoor Type
	Painting Colour : Manufacturer Standard
	Air Cylinder

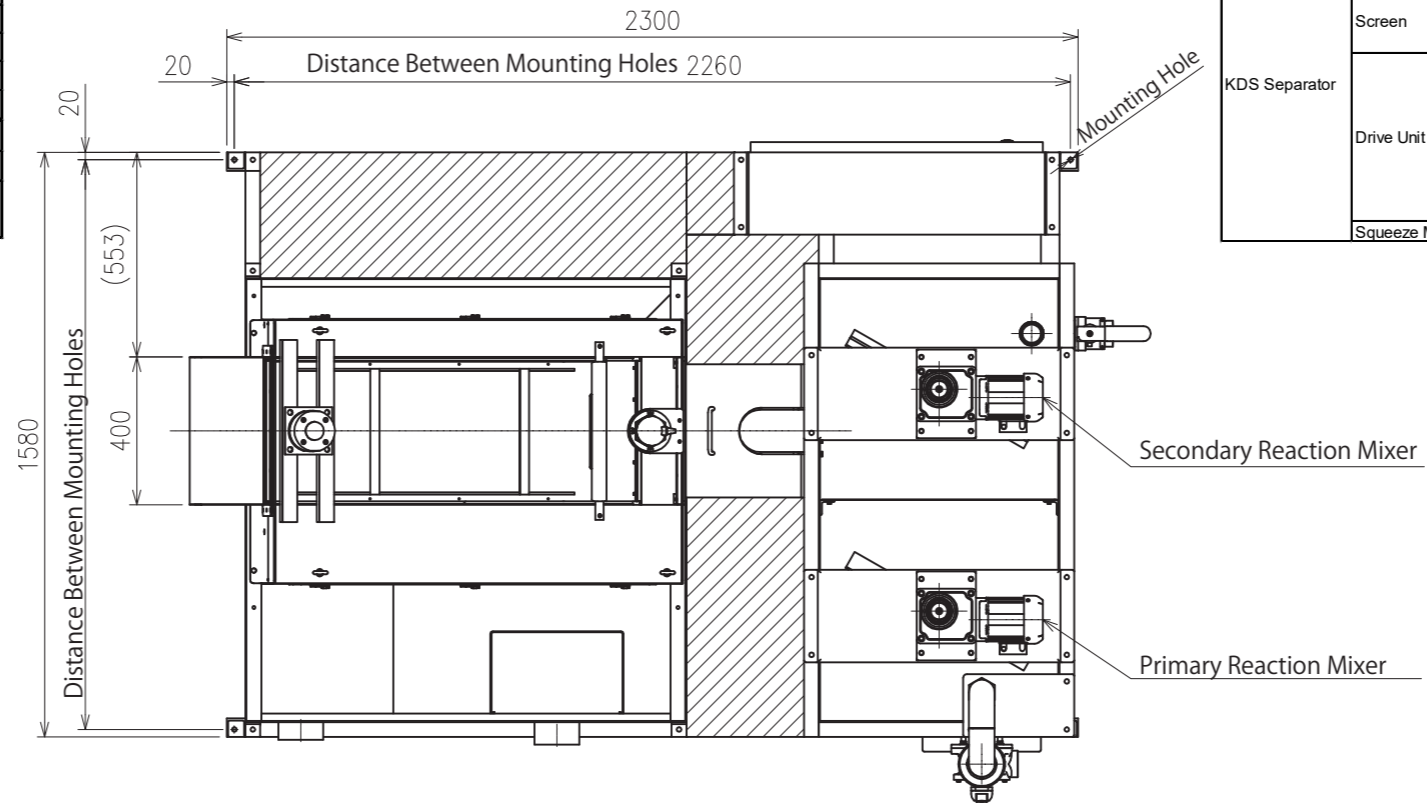

Compressor placed separatory

Drawing for Reference

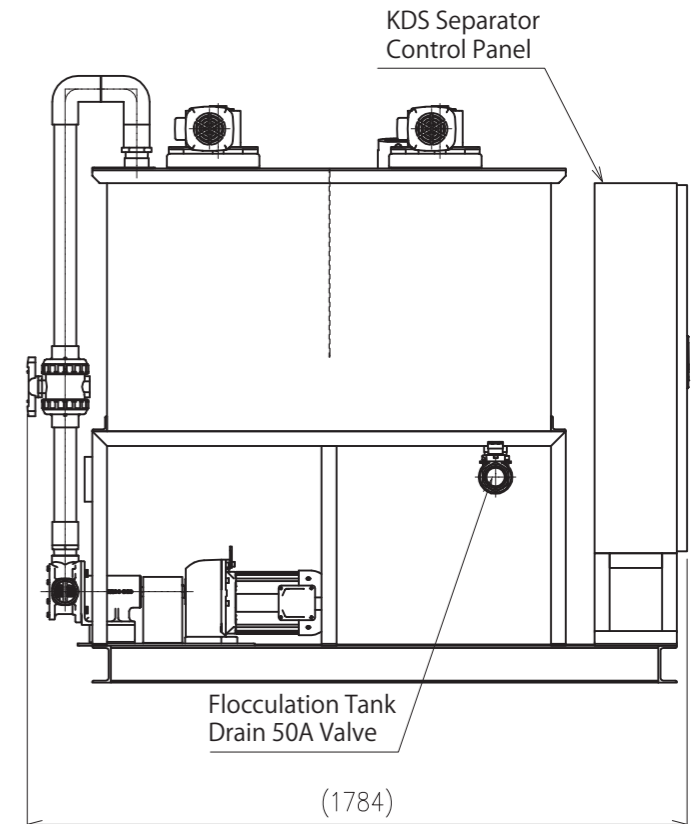
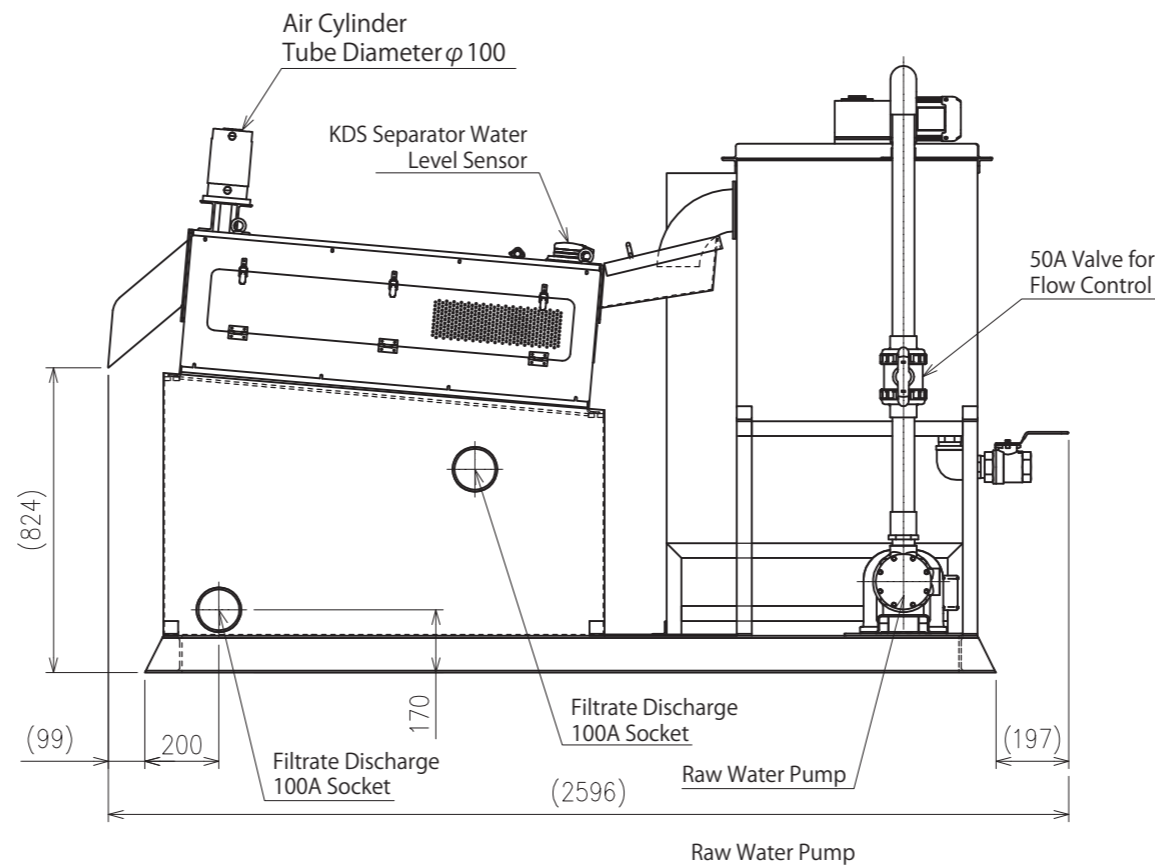
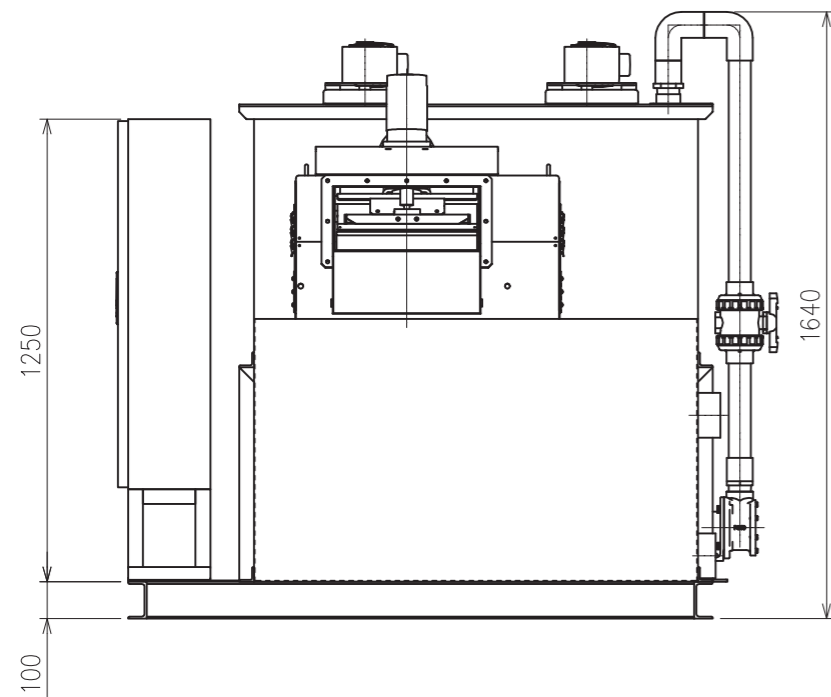

The drawing is for reference only and subject to change without notice.

△	-	・	-	製図	-	-
△	-	・	-	設計	-	-
△	-	・	-	DESIGNED	-	-
△	-	・	-	検図	-	-
△	-	・	-	CHECKED	-	-
△	年月日	記事	訂正者	承認	-	-
MARK	DATE	CONTENT	REVISED	APPROVED	-	-



株式会社 研電社  
KENDENSHA Co.,Ltd

品番/ITEM NO.	型式/MODEL	図面名称/DRAWING NAME	装置名称/UNIT NAME	単位 UNITS	尺度 SCALE	サイズ SIZE	変更回数 REV.
-	SS-411D	Outline Drawing	SS-411D Dewatering System	mm	1:20	A3	△
工番/JOB NO.	図面番号/DRAWING NO.	御客様社名/CLIENT		投影法 PROJECTION	年月日 DATE		
-	-	-	-	第一角法	2021.01.06		