

Details of Terminal Block

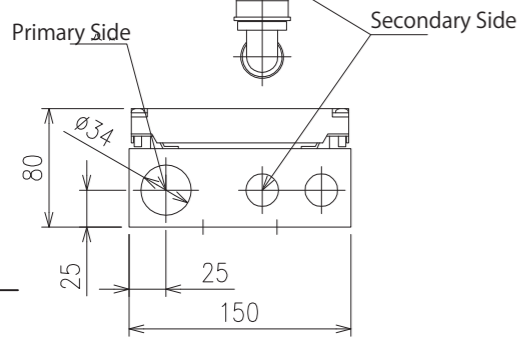

Outline of Terminal Box

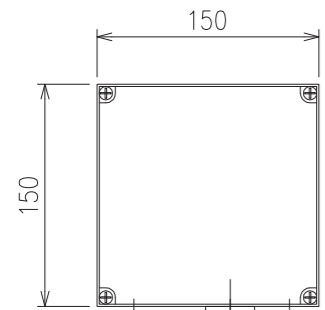
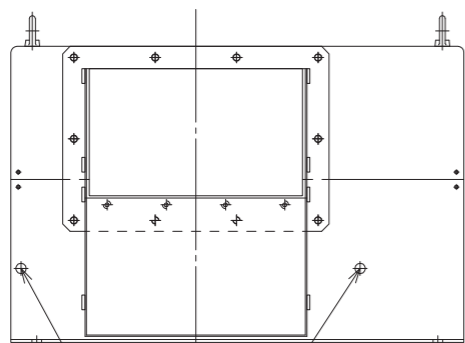

Grease Fittings

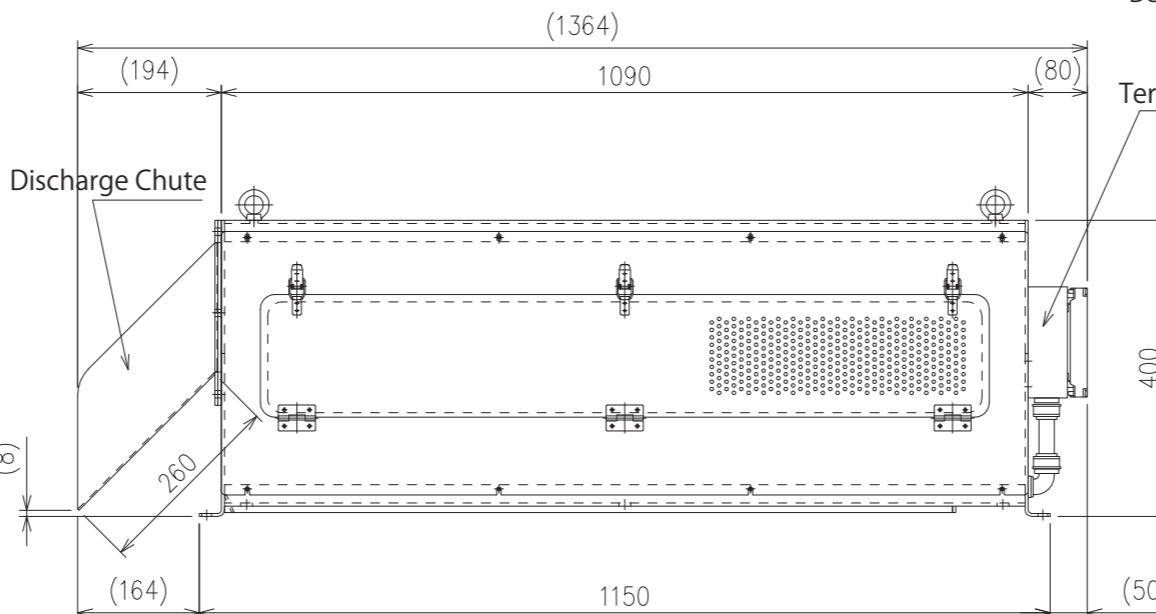
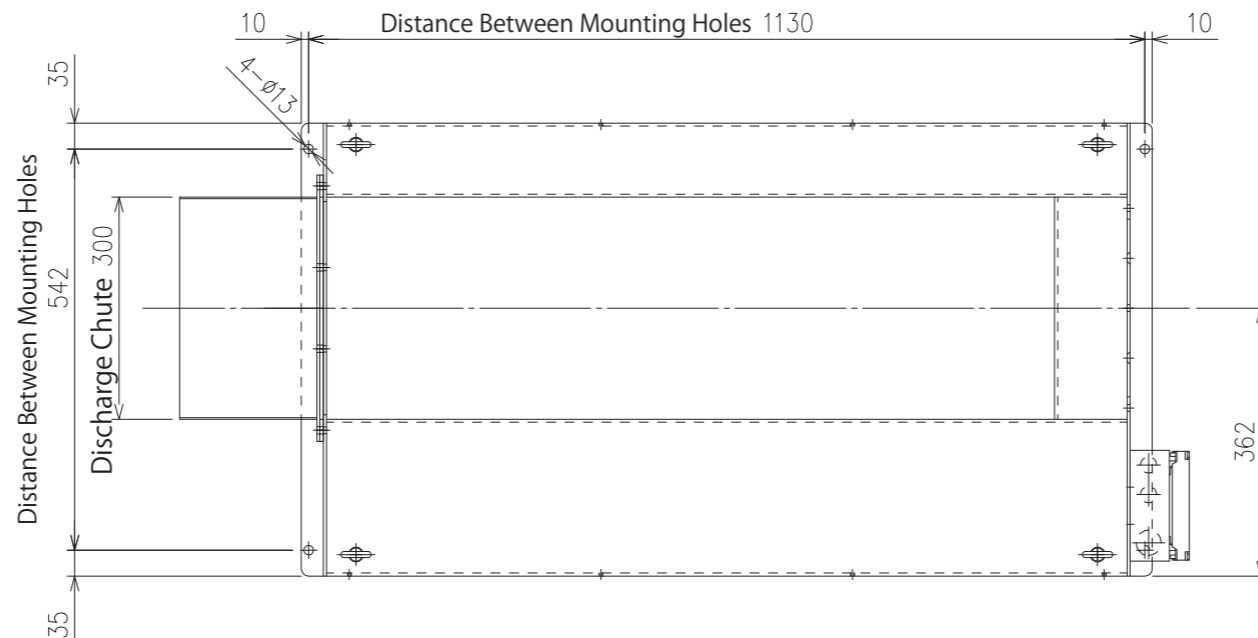

Specification		
Model	SS-312	
Casing	Material: SUS 304 Thickness: 4.0mm	
Rotating Shaft	Material: SUS 304	
Screen	Flow Passage Width	280mm
	Rotating Oval Plates	12 rows (Material: SUS301-CSP t0.5)
	Gap	1.0mm
	Fixed Flat Bars	3mm x 10mm
Drive Unit	Gear Motor	
	3φ 200V 0.1kw	
	Reduction Gear Ratio	1:150
	Revolution Speed	10.0r/min(50Hz), 12.0r/min(60Hz)
	Rated Current Value	1.24A(50Hz), 1.09A(60Hz)
	Class E Insulation, TEFC Outdoor Type	
Painting Colour	Manufacturer Standard	
Approx. Weight	180kg	

Caution: Do not reverse the motor rotation.

Drawing for Reference

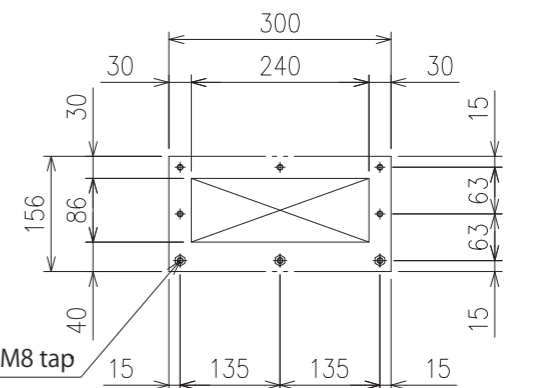

Inflow Flange Mounting Area

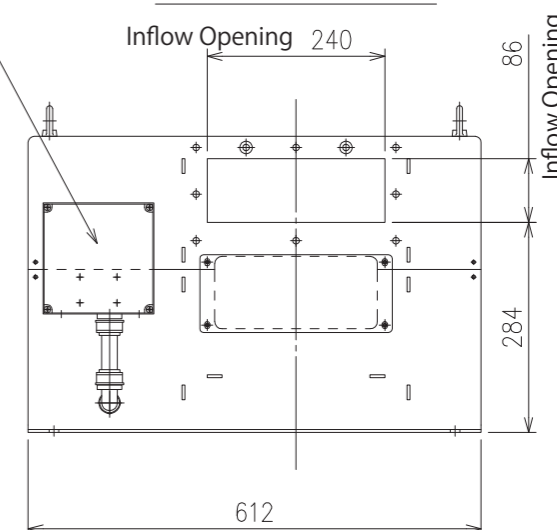

The drawing is for reference only and subject to change without notice.

△	-	・	-	製図	-	-
△	-	・	-	設計	-	-
△	-	・	-	DESIGNED	-	-
△	-	・	-	検図	-	-
△	-	・	-	CHECKED	-	-
△	年月日	記事	訂正者	承認	-	-
MARK	DATE	CONTENT	REVISED	APPROVED	-	-

株式会社 研電社  
KENDENSHA Co.,Ltd

品番/ITEM NO.	型式/MODEL	図面名称/DRAWING NAME	装置名称/UNIT NAME	単位 UNITS	尺度 SCALE	サイズ SIZE	変更回数 REV.
-	SS-312	Outline Drawing	Thickening Model	mm	1:10	A3	△
工番/JOB NO.	図面番号/DRAWING NO.	御客様社名/CLIENT		投影法 PROJECTION	年月日 DATE		
-	-	-	-	第一角法	2021-01-06		